



PREDICTORS OF JOB STRESS ON WORK ENGAGEMENT

Beena Joice M¹ | Dr. R.Magesh²

¹ Assistant Professor, Gnanam School of Business, Thanjavur, Tamil Nadu, India.

² Associate Professor, DOMS, Anna University, Chennai, Tamil Nadu, India.

ABSTRACT

Education and training sector is undergoing a sea change in the recent past with the focus shifted from public to private sector. Private sector is also actively involved in education and its role will become more poignant in days to come. Work engagement of Indian teachers is highly needed because studies revealed several problem areas could influence their work engagement. Researchers have indicated various job stressors which include –individual characteristics and approach towards his or her job, coping inabilities, role ambiguity, work relationship, physical environment, role conflict etc. The primary objective of the study is to assess the factors predicting work engagement among the teachers in the Private Schools. The researcher has chosen a particular region for the research to be carried out. The area covered is Thanjavur District with the sample size of 300.

Keywords: Predictors of work engagement, Job Stress, Personality trait, Coping Strategies.

Introduction:

Education sector is undergoing a sea change in the recent past with the focus shifted from public to private sector. The private sector's role in the higher education sector has been growing at a rapid pace over the last decade and needs to further expand at an accelerated rate. The education market is now thriving on the back of the workforce proving itself equal to their counterparts elsewhere in the world in productivity.

Work engagement of Indian teachers is highly needed because studies revealed several problem areas could influence their work engagement. Few dissatisfaction factors are found like lack of peer relation, increased job stress level, poor relations between management and staff among the teachers leading to reduced work engagement. All of these factors could inhibit the work engagement of the teachers. Students who observed de-motivated teachers also became unenthusiastic. Rollinson (2005) defines workplace stress as conditions which inhibit employees to perform normally in workplace. The conditions are termed as stressors – the potential sources that cause stress.

Researchers have indicated various job stressors which include –individual characteristics and approach towards his or her job, coping inabilities, role ambiguity, work relationship, physical environment, role conflict etc. Work engagement is highly affected by job resources. Job resources provide employees with psychological autonomy and more concentration. Inadequacies of these resources cause stress which affect employee's work in terms of satisfaction and involvement.

Literature Review

Rothmann, Welsh (2013) investigated the antecedents of work engagement and finding implies that employees, who feel depleted because of work demands, may experience psychological meaningfulness.

Ramos, Ales, Sierra (2013) focused on the role of work engagement as antecedents of job satisfaction and the result of

this research support that there is a strong correlation between role stress and work engagement and negatively correlated to work engagement.

Tanzil Khan (2012) explains in his study that extent of burnout among full time faculty at Fullerton College. The result shows that female faculty burnout soon and 57% of the faculty gets burnout leading to low work engagement.

Handa and Gulati (2014) found personality as a significant predictor of work engagement and identified positive relationship between the personality traits and work engagement.

Galves, Dickinson and Maria(2005), in their study compared relationships among perceived stress, stress-coping strategies, and health-related quality of life (HRQL) in a rural sample of Mexican citizens living in the United States, Mexican-Americans, and non-Hispanic whites. The study has identified that higher level of perceived stress were associated with the higher numbers of chronic health problems.

Arti Devi (2012) aimed to identify the coping strategies used for managing role stress at commercial banks. The research has identified that the employees of the commercial banks attempt to manage role stress by adopting and applying various coping strategies. Coping dimensions imply as one of the stress management interventions.

Kapil, Kulshrashtra (2014) main objective of the study was to explore the job aspects leading to stress and also to identify the stress management techniques by the Doctors. The research has identified many factors leading to stress among stressors in which 64% constitute to the lack of peer support and 74% constitute to work related pressure. The study has been found that by adopting certain strategies, the stress level can be managed.

Schaufeli & Bakker, (2004) Work engagement, intrinsic motivation and job satisfaction – the three key drivers to the

competitive advantage of an organization – were correlated with employees’ attitudes towards work.

Objectives of the study

- The primary objective of the study is to assess the factors predicting work engagement among the teachers in the Private Schools.
- To study the significance and influence of Personality Trait, Individual Coping Strategies, Perceived Organizational support and Job stress on Work Engagement.
- To suggest the possible measures to increase the work engagement level.

Research design and Methodology

- Research Type - Quantitative research
- Research design - Descriptive cross sectional research
- Primary data design - Private Schools Thanjavur District.
- Data collection method - Online Survey method, Personal visit.
- Sampling method - Population study
- Sampling location & size - Thanjavur & 300
- Data collection Instrument - Structured questionnaire

Hypothesis

- H1: There is positive influence Personal Trait on work engagement
- H2: There is negative influence of Perceived Organization Support on work engagement.
- H3: There is negative influence of Individual Coping Strategy on work engagement.
- H4: There is negative influence of Work Stress on work engagement.

Conceptual Model

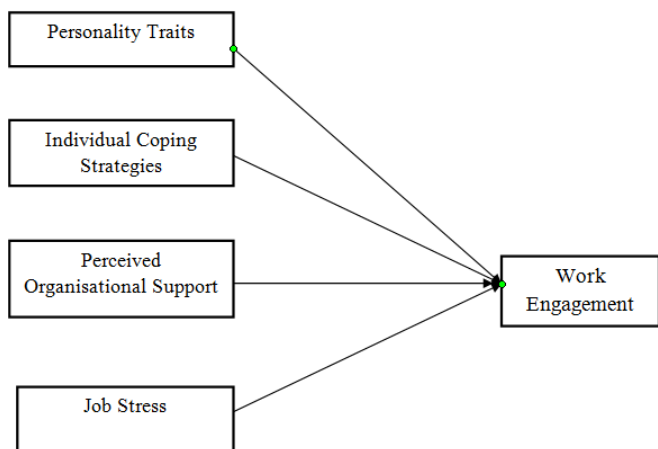

Data Analysis and Interpretation

Table:1-Frequency Distribution

		Statistics						
		Gen der	Age	Marita l status	Edu catio n	Work_ Experi ence	House hold_A nnu al_ Incom e	Depa rtmen t
N	Valid	300	300	300	300	300	300	300
	Miss ing	0	0	0	0	0	0	0
Mean		1.59	1.92	1.49	2.45	2.02	2.35	3.94
Std. Error of Mean		.028	.055	.037	.066	.071	.062	.110
Median		2.00	2.00	1.00	2.00	1.00	3.00	4.00
Mode		2	1	1	2	1	3	3
Std. Deviation		.492	.955	.641	1.139	1.233	1.066	1.897
Variance		.242	.913	.411	1.298	1.521	1.137	3.598
Skewness		-.382	.376	.957	.235	.903	-.011	.145
Std. Error of Skewness		.141	.141	.141	.141	.141	.141	.141
Kurtosis		-1.867	-1.375	-.172	-1.372	.011	-1.319	-1.152
Std. Error of Kurtosis		.281	.281	.281	.281	.281	.281	.281
Range		1	3	2	3	5	3	6
Minimum		1	1	1	1	1	1	1
Maximum		2	4	3	4	6	4	7
Sum		478	575	447	734	607	704	1181
Perce ntiles	25	1.00	1.00	1.00	2.00	1.00	1.00	3.00
	50	2.00	2.00	1.00	2.00	1.00	3.00	4.00
	75	2.00	3.00	2.00	4.00	3.00	3.00	6.00

- From The Above Data, It Can Be Observed That From The Number Of Teachers Who Answered The Questionnaire Contained Mostly Female Population Than The Male Population.
- Respondents were higher number on 25-30 years with 47%, 31-40 years with 17.3%, 41-50 years with 32.7% and 51-60 years with 9%.
- The Number of Teachers are mostly Single than the Married and Widowed.

- Respondents were higher number in PG Comparing with UG, M.Phil, and Others.
- The Respondents with Work Experience were higher number in years in Less than 5 years comparing to others.

Regression Analysis

Table 2:Regression Weights: (Group number 1 - Default model)

			Estimate	S.E.	C.R.	P	Label
WE	<---	PTT	.134	.060	2.258	.024	
WE	<---	ICS	-.199	.059	3.398	***	
WE	<---	WJS	-.117	.053	2.197	.028	
WE	<---	POS	-.106	.058	1.925	.047	

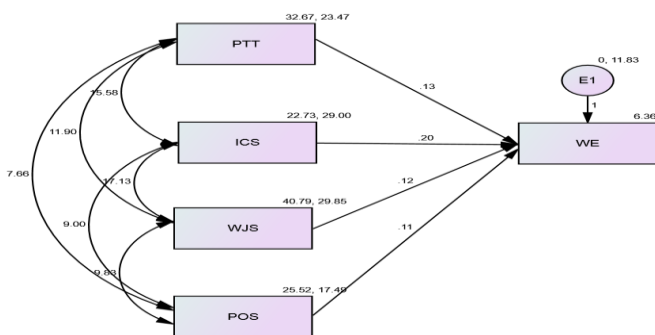

Confirmatory factory analysis

The objective of confirmatory factor analysis is to test whether the data fit a hypothesized measurement model.

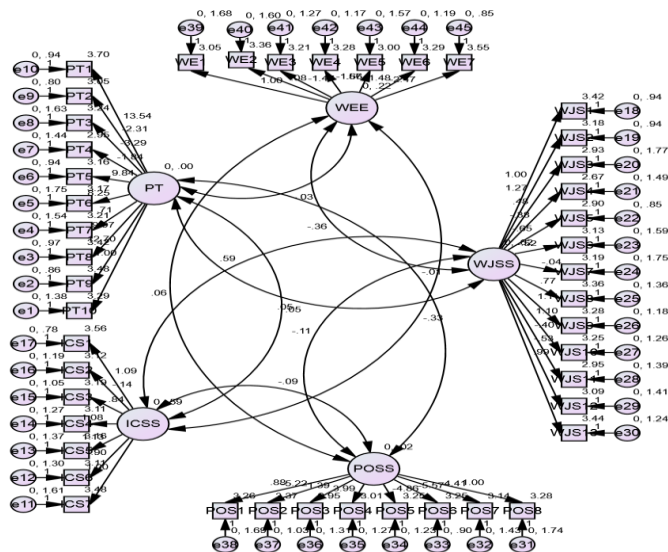

Table 3 :RMSEA

Model	RMSEA	LO 90	HI 90	PCLOSE
Default model	.054	.050	.059	.069
Independence model	.106	.103	.110	.000

Model	RMSEA	LO 90	HI 90	PCLOSE
Default model	.054	.050	.059	.069
Independence model	.106	.103	.110	.000

The RMSEA value is .054 < 0.80, hence the model is validated as fit model.

FINDINGS

- All employees having opinion that more Organization support is necessary to increase productivity. Organization has to provide enough authority to perform duties effectively.
- The study results revealed that there is a strong positive influence of Personality Trait and negative influence of Perceived Organization support, Individual Coping Strategies, Job Stress on work engagement.
- The proposed model is also fit according to the test of Confirmatory Factor Analysis and the hypotheses are proved.
- Individual Coping Strategies, Personality trait and Work Stress have influenced higher than the Perceived Organizational Support which indicates the level of prediction on Work Engagement.

SUGGESTIONS

- Schools should concentrate more on Interpersonal skill training program to make the employees more comfortable according to his or her own characters.
- Frequent training programs or stress intervention programs to be given to the teachers to enable themselves to adopt the suitable coping mechanisms.
- To overcome the problem in Support from Organization, the employers should bring about some changes in their Organizational Support towards the employee which are being followed.
- With the Job/Work Stress, it is proved that most of the employees are influenced in high level so management should take necessary steps to resolve.
- Individual Perception towards the Organization must be analyzed and management should take responsibility for that by addressing the issues.

Future research

Considering the study on Personality traits, Individual coping strategy, Perceived Organization support and work engagement among teachers in private schools in Thanjavur District, it will be important to investigate these aspects on a larger scale (to include other part of Tamilnadu or India as whole) so as to have an in-depth understanding of these constructs holistically.

Conclusion

Based on conceptual framework, the current study sought to examine the relationship between Personality trait, Individual Coping strategy, Perceived Organization support, Job stress and work engagement in an attempt to better understand how

these variables influence work engagement levels at work. Regression results indicate that Personality trait was a predictor to work engagement. A significant positive relationship was found indicating that Work Stress can influence work engagement levels. This finding provides statistical evidence for the conceptual framework presented. However, the hypothesized relationship between Perceived Organization Support and work engagement was not influenced fully. Lack of significance of this relationship indicates that Perceived Organization Support does not predict how engaged one is on their job.

Optimism and risk for burnout among working college students: Stress as a mediator. Personality and Individual Differences

15. Chambel, M. J., & Cural, L. (2005). *Stress in academic life: Work characteristics as predictors of student wellbeing and performance.*

16. Wilmar b. schaufeli & marisa salanova(2007) *Efficacy or inefficacy, that's the question: Burnout and work engagement, and their relationships with efficacy beliefs*

REFERENCES

1. Amy (2009) *Relationship between occupational stress and job satisfaction. The economic journal,34*

2. Sahil MaliK and Geetika Malik (2015) *Social Support at Workplace with Engagement*

3. *and Retention Behavior of Generation Y Employees. Advances in Economics and Business Management (AEBM) Volume 2, Number 3*

4. Sukanlaya Sawang and Cameron J. Newton (2014) *Psychological stress and employee engagement*

5. Chughtai, A. A., & Buckley, F. (2008). *Work engagement and its relationship with state and trait trust: A conceptual analysis. Journal of Behavioral and Applied Management, 10(1).*

6. Joseph, goodman, randy evans, and charles , carson (2011) *Organizational Politics and Stress:Perceived Accountability as a Coping Mechanism .The journal of business inquiry volume-1*

7. Nanik Ram, Immamuddin Khoso, Asif Ali Shah (2011) *Role conflict and role ambiguity as factors in work stress among managers*

8. Frank, F.D., Finnegan, R.P. and Taylor, C.R. (2004) *The race for talent: retaining and engaging workers in the 21st century, Human Resource Planning, 27(3)*

9. Salanova, M. (2007). *Efficacy or inefficacy, that's the question: Burnout and work engagement, and their relationships with efficacy beliefs. Anxiety, Stress, and Coping*

10. Ganster, D. C., & Schaubroeck, J. (1991). *Work stress and employee health. Journal of Management*

11. Esther Chang and Karen Hancock *Role stress and role ambiguity in new nursing graduates in Australia*

12. Chapman J. (1993) *Collegial support linked to reduction of Job stress. Nursing Management.*

13. Kahn, W. A. (1990). *Psychological conditions of personal engagement and disengagement at work.*

14. Chang, E. C., Rand, K. L., & Strunk, D. P. (2000).