



# AN ANT COLONY OPTIMIZATION ALGORITHM TO SOLVE THE BROKEN LINK PROBLEM IN WIRELESS SENSOR NETWORK - A REVIEW

\*Minakshi<sup>1</sup> | Monika Bansal<sup>2</sup>

<sup>1</sup> M-tech Student, Department of Computer science & Application, Devi Lal University, Sirsa, Haryana, India.

(\*Corresponding Author)

<sup>2</sup> Assistant Professor, Department of Computer science & Application, Chaudhary Devi Lal University, Sirsa, Haryana, India.

## ABSTRACT

ACO is a well-known metaheuristic in which a colony of artificial ants cooperates to explain a good solution to a combinatorial optimization problem. Wireless sensor networks consisting of nodes with limited power is deployed to gather useful information from the field. In wireless sensor networks it is critical to collect the information in an energy-efficient manner. Ant colony optimization, a swarm intelligence-based optimization technique, is widely used in network routing.

A novel routing approach using an ant colony optimization algorithm is proposed for wireless sensor networks consisting of stable nodes. Illustrative example details, description, and cooperative performance test results of the proposed approach are included. The approach is also implemented on a small-sized hardware component as a router chip. Simulation results show that the proposed algorithm provides a promising solution, allowing node designers to efficiently operate routing tasks.

**KEYWORDS:** Threshold Value (Load on Node), Noise Variance, Request Timeout/Backoff Attempt, Slot Time, Turnaround Time, MaxRetries.

## INTRODUCTION

Wireless Sensor Networks have become a wide area for research. Wireless Sensor Networks (WSN) has gained world-wide attention in recent years. It is a sensing technology where autonomous devices called sensor nodes are deployed in a remote area to observe phenomena, collect data and process it and then transmit information to users via radio frequency (RF) channel [1][2].

The concept of wireless sensor networks is based on a simple equation: Sensing + CPU + Radio = Thousands of potential applications [3].

### 1.1 Sensor Networks

A sensor network is a consisted of communicating sensing devices, or nodes. All nodes are not necessarily communicating at any particular time, and nodes can only communicate with a few nearby nodes. The network has a routing protocol to control the routing of data messages between nodes. The routing protocol also attempts to get messages to the base station in an energy-efficient manner.

### 1.2 Wireless sensor node architecture

Wireless sensor node is made up four basic components: a sensing unit, a processing unit, a transceiver unit and a power unit.

There can be application dependent additional components such as a location finding system, a power generator and a mobilizer [4].

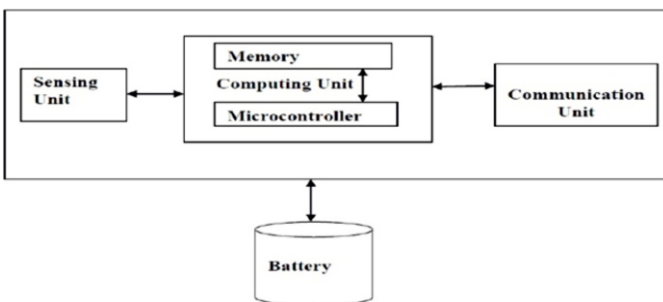

Figure 1. Architecture of Wireless Sensor Node

**Sensing Unit:** Sensing units are usually composed of two subunits: sensors and analog to digital converters (ADCs). Sensor is a device which is used to translate physical phenomena to electrical signals.

**Processing Unit:** The processing unit mainly provides intelligence to the sensor node. The processing unit consists of a microprocessor, which is responsible for control of the sensors, execution of communication protocols and signal processing algorithms on the gathered sensor data.

**Transceiver Unit:** The radio enables wireless communication with neighbouring nodes and the outside world. It consists of a short range radio which usually

has single channel at low data rate and operates at unlicensed bands of 868-870 MHz (Europe), 902-928 MHz (USA) or near 2.4 GHz (global ISM band).

**Battery** - The battery supplies power to the complete sensor node. It plays a vital role in determining sensor node lifetime. The amount of power drawn from a battery should be carefully monitored.

### 1.3 Applications of Wireless Sensor Networks

**Military applications:** The various characteristics of WSNs like self-organization and fault tolerance, make them a very reliable sensing technique for military command, communications, computing, intelligence, surveillance, and targeting systems. [4,5,6]

**Environmental applications:** Wireless Sensor Networks have been deployed for environmental monitoring, which involves tracking the movements of small animals and monitoring environmental conditions that affect crops and livestock.

**Healthcare applications:** WSN based technologies such as Ambient Assisted Living and Body Sensor Networks provide dozens of solutions to healthcare's biggest challenges such as an aging population and rising healthcare costs [7]

**Traffic control:** Traffic conditions can be easily monitored and controlled at peak times by WSNs. Temporary situations such as roadwork and accidents can be monitored in situ. Further, the integration of monitoring and management operations, such as signpost control, is facilitated by a common WSN infrastructure.

### 1.4 Problem Definition

Energy efficiency and reliability have become one of the principle design features of successful sensor networks. In wireless networks balancing the use of power and maintaining the reliable communication is a really very challenging job. Research has focused on ways to minimize energy usage in routing to maximize the useful lifetime of sensor networks and also on reliability in case of a failure like presence of an attacked node.

### 1.5 Existing Techniques for Energy Efficiency in WSNs

The following are the already proposed algorithm and techniques for energy optimization of the Wireless Sensor Networks.

- Path selection Algorithm
- Clustering Algorithm
- Sleep Mode Markov Model
- Cross Layer Protocol for Energy Efficiency
- Error control schemes analysis

## RESEARCH METHODOLOGY

### 2.1 Base Algorithms used

Our proposed algorithm is based on two basic approaches:

1. Right Path Selection algorithm
2. Ant Colony Optimization algorithm

2.2 Proposed Algorithm

- 1. Source: Route Request
- 2. Destination: Route Reply
- 3. Source: for  $k=[0 \text{ to } n-1]$
- 4. Source: Find "Right Path"  $\pi_i$  for  $(p_1, p_2, \dots, p_n)$
- 5. if  $\pi_i = \text{BROKEN\_LINK}$  and  $\text{No\_of\_Retry} > \text{Threshold}$  then
- Call  $\text{AntOptimization}()$ ; /\* to find the optimized path one time\*/
- 6. If  $E_{a,\pi_i} > E_{c,\pi_i}$  then Calculate  $S_{\pi_i}$  (selectivity of path  $\pi_i$  in round  $k$ th) Else goto step 4
- 7. If  $S_{\pi_i} = \text{Max}(S_{\pi_1}, \dots, S_{\pi_n})$  then
- If  $k < n-1$  then
- $k = k + 1$
- goto step 3
- Else goto step 7
- Else goto step 3
- 8. stop
- }
- Function  $\text{AntOptimization}()$
- {
- 1. {Initialization}
- Initialize pheromone concentration  $T_{ij}$  and heuristic function  $\eta_{ij}$ .
- 2. {Construction}
- For each node  $k$  (currently in state  $i$ ) do
- repeat
- choose in probability the state to move into.
- append the chosen move to the  $k$ -th node's set  $\text{tabu}_k$ .
- until node  $k$  has completed its solution.
- end for
- 3. {Trail update}
- For each ant move  $(i, \psi)$  do
- Compute  $\Delta \tau_{i, \psi}$
- update the trail matrix.
- end for
- 4. {Terminating condition}
- If not(end test) go to step 2
- }

2.3 Simulation Environment:

Here we used MATLAB 7.8.0 as simulation platform. MATLAB is high-performance language for technical computing, visualization, and programming in an easy-to-use environment where solutions are expressed in mathematical notation.

RESULTS

The objective of our simulation is to demonstrate the increased network lifetime by choosing the right path. The proposed algorithm was validated using the simulator in MATLAB. The network topology is created by randomly placing the sensor nodes in the area of 100 by 100 meters. The simulation results show similar performance in terms of the increased network lifetime.

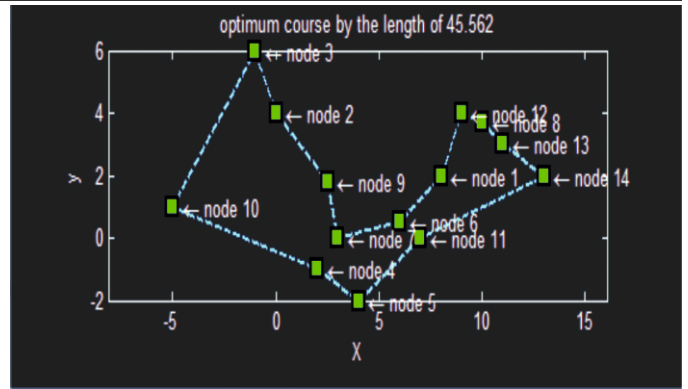

Figure 2: Path selected by proposed algorithm

3.1 Results of Proposed Algorithm

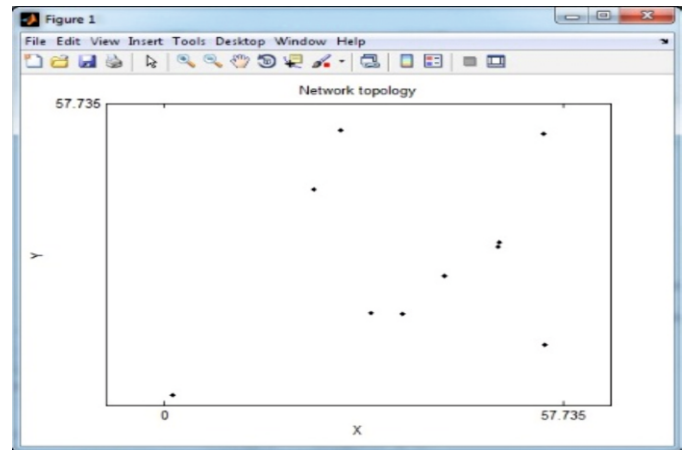

Figure 3: Network Topology for Proposed Algorithm

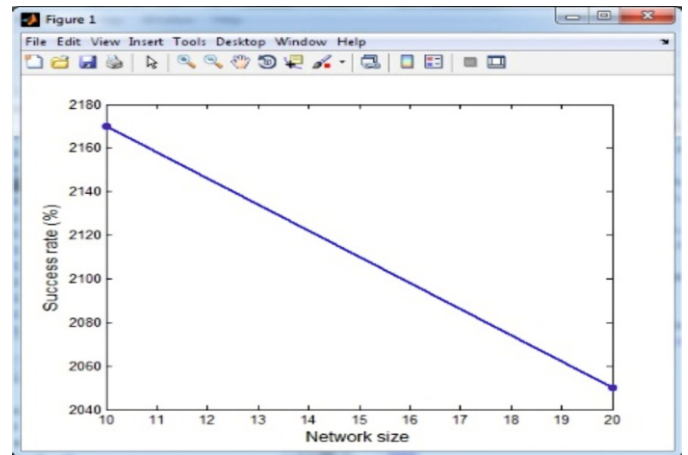

Figure 4: Success Rate Vs Network Size

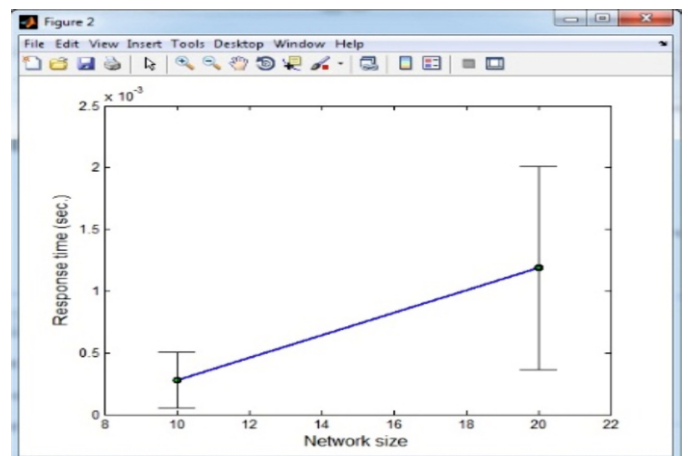

Figure 5: Response Time (sec.) Vs Network Size

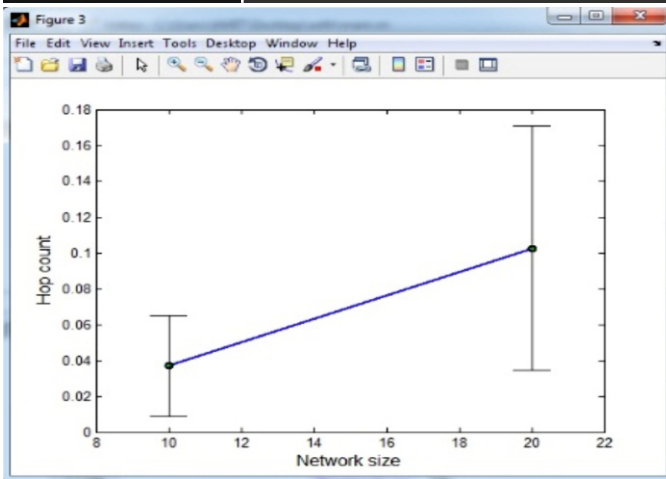

Figure 6: Hop Count Vs Network Size

### CONCLUSION

In this research work, an energy-saving strategy that exploits the combination of Path Selection and Ant Optimization techniques in Wireless Sensor Networks has been developed. By simulation, we have found out that the energy in our protocol is dissipated less than the other energy-aware routing protocols. By default

the route is chosen on the basis of Path Selection formula i.e. we will choose right path means the lowest energy path. In case there is problem in the selection of the path (in case of any fault node) then we apply the Ant Colony Algorithm the purpose of which is to continue sending data using the previous path (as from Path Selection Algo.). Hence we achieved efficiency in terms of energy by applying path selection whereas Ant Colony Optimization Algorithm gives the required reliability.

### REFERENCES

1. Singh, G., Das, S. Gosavi, S., Pujar, S. Ant Colony Algorithms for Steiner Trees: An Application to Routing in Sensor Networks. In Recent developments in Biologically Inspired Computing; de Castro, L.N., Von Zuben, F.J., Eds.; Idea Group Publishing: Hershey, USA, 2004; pp. 181-206.
2. P. Liu, Y.F. Hu, G. Min, G. Dai, "Semantization improves the Energy efficiency of Wireless Sensor Networks", IEEE Communications Society subject matter experts publication WCNC, 2010.
3. Kashif Saleem, Norsheila Fisal, M. Ariff Baharudin, Adel Ali Ahmed, Sharifah Hafizah, Sharifah Kamila, Ant Colony inspired Self-Optimized Routing Protocol based on Cross Layer Architecture for Wireless Sensor Networks, ISSN, Volume 9, October 2010, 1109-2742.
4. Sanatan Mohanty " Energy Efficient Routing Algorithms for Wireless Sensor Networks and Performance Evaluation of Quality of Service for IEEE 802.15.4 Networks", Master thesis, National Institute of Technology, Rourkela, January 2010
5. Sensor Networks: A Comparative Study" [ Communications, 2004 IEEE International Conference on] communications.
6. Hussein T. Mouftah, "Advances in WSN", University of Ottawa, February, 2008.
7. "Wireless Sensor Networks Technology, Protocols, and Applications" Kazem Sohraby, Daniel Minoli, Taieb Znati, A John Willy & Sons, Inc Publications, 2007.